

# ConnectBox

Connecting devices

## MODBus Products

- Protocol Gateway
- Datalogger
- Internet Access
- SNMPv3
- Web Server



Modbus Server (Slave) Gateway configuration for integration of third party systems into Modbus based control systems

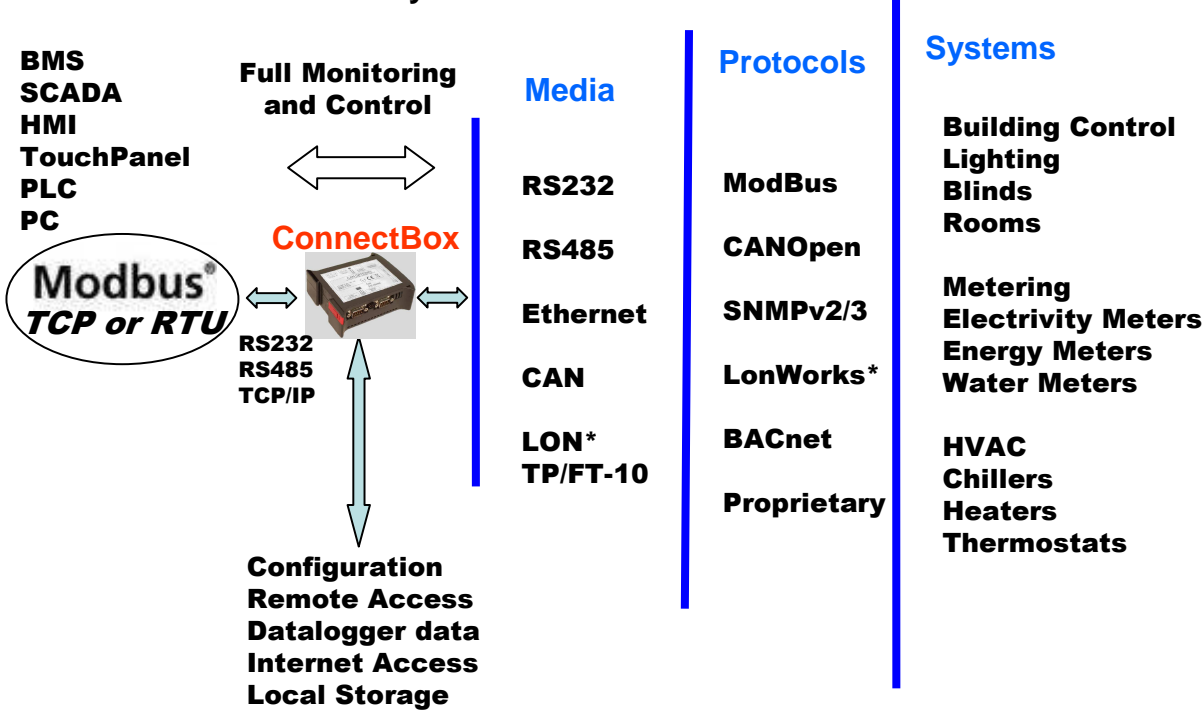

ConnectBox – connecting devices [www.m3t.it](http://www.m3t.it)



# ConnectBox

## Connecting devices

Modbus master (Client) Gateway configuration for integration of Modbus devices into other control systems ( SNMP, Modbus, BACnet, etc)

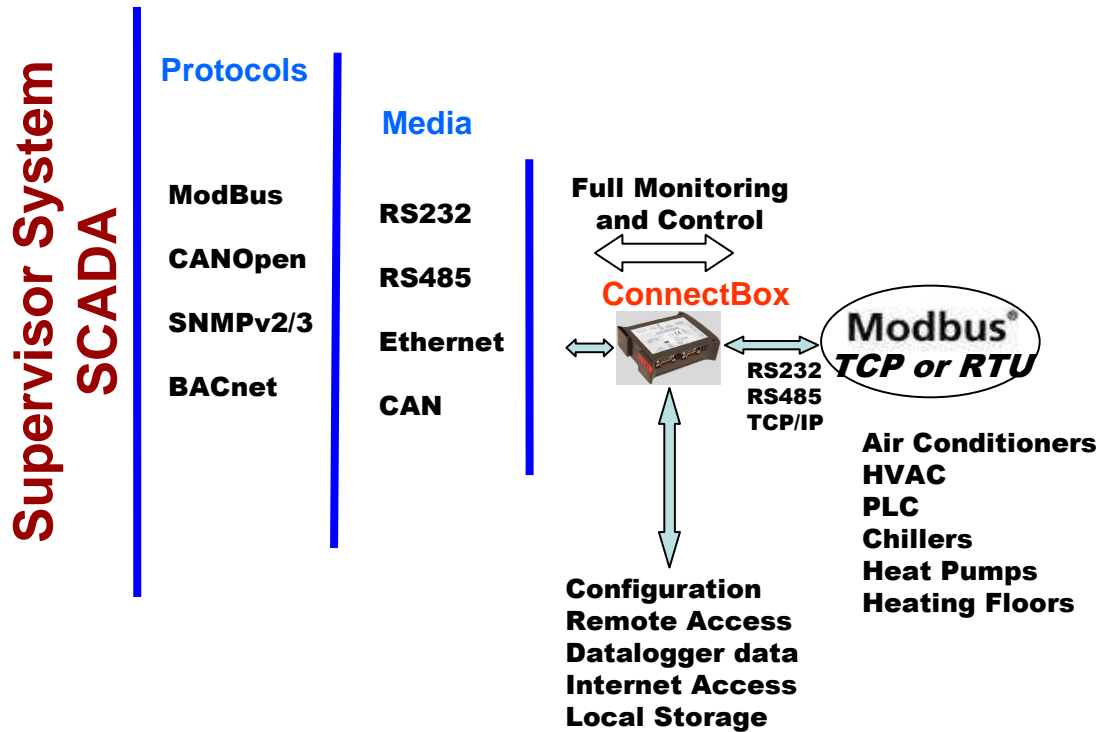

### Technical Specification

Interfaces	n.2 RS232/RS422/RS485 communication ports n.1 RS232 communication port n.1 CAN port n.2 USB 2.0 n.1 SDIO slot n.1 Ethernet 10/100Mbps n.3 LEDs
Protocols	BACnet Master/Slave CANbus 2.0 (Master) MODbus RTU (Master) MODbus IP (Slave) Proprietary protocols
Management	HTTP Web server with authentication SNMPv3
Power supply	12-24 VCC/VAC

